



**SX4**<sup>TM</sup>

Winchester<sup>®</sup> Super X<sup>®</sup> 4, Autoloading Shotgun Owner's Manual

Important instructions for the

# Winchester® Super X®4 Autoloading Shotgun

Winchester Repeating Arms  
Customer Service Department (United States)  
275 Winchester Avenue  
Morgan, Utah 84050-9333  
Phone: (800) 945-5237

If you have any questions or comments regarding your new firearm, please feel free to write or call us. Use the space below to record information about your new firearm.

Model \_\_\_\_\_

Serial Number \_\_\_\_\_

Purchased From \_\_\_\_\_

Date of Purchase \_\_\_\_\_

Winchester is a registered trademark of Olin Corporation.



Specifications within this owner's manual are correct at the time of printing and subject to change without notice.

<b>Contents</b>	<b>Page</b>
State Warning . . . . .	1
WARNING: You Are Responsible For Firearms Safety . .	1
General Description and Operation . . . . .	6
Nomenclature . . . . .	8
Serial Number . . . . .	8
Initial Cleaning and Oiling . . . . .	8
Operation of the "Safety" . . . . .	9
Assembly . . . . .	12
Disassembly . . . . .	14
Ammunition . . . . .	14
Magazine Capacity . . . . .	16
Three-Shot Adaptor (Plug) . . . . .	16
Loading . . . . .	18
Firing . . . . .	21
Unloading . . . . .	22
Interchangeable Choke Tube System . . . . .	22
Scope Mounting Instructions . . . . .	25
Extra Barrels . . . . .	26
Length of Pull Adjustment . . . . .	27
Cleaning and Maintenance Suggestions . . . . .	28
Servicing the Trigger Group and Bolt Assemblies . . . .	30
Parts, Service, Repair and Questions . . . . .	36
Website Information . . . . .	37

## STATE WARNING

---

According to state law, California requires that firearm manufacturers, distributors and retailers include conspicuous, specific warnings with firearms sold in that state.

 <b>WARNING</b>	 <b>ADVERTENCIA</b>
<p>Firearms must be handled responsibly and securely stored to prevent access by children and other unauthorized users.</p> <p>California has strict laws pertaining to firearms, and you may be fined or imprisoned if you fail to comply with them. Visit the Web site of the California Attorney General at <a href="https://oag.ca.gov/firearms">https://oag.ca.gov/firearms</a> for information on firearm laws applicable to you and how you can comply.</p> <p>Prevent child access by always keeping guns locked away and unloaded when not in use. If you keep a loaded firearm where a child obtains and improperly uses it, you may be fined or sent to prison.</p>	<p>Las armas de fuego deben de ser manipuladas responsablemente y almacenadas en sitios seguros para prevenir el acceso a ellas por parte de niños y personas sin autorización.</p> <p>California cuenta con leyes estrictas sobre las armas de fuego, y puede ser multado y encarcelado si no las obedece. Visite la página web de California Attorney General, <a href="https://oag.ca.gov/firearms">https://oag.ca.gov/firearms</a> para más información sobre cómo cumplir con las leyes de armas de fuego.</p> <p>Preveniga el acceso de los niños a las armas de fuego manteniéndolas siempre en un lugar seguro, bajo llave y descargadas cuando no estén en uso. Si usted deja un arma cargada al alcance de un niño, y éste la utiliza indebidamente, usted podría ser multado e incluso enviado a la cárcel.</p>

## WARNING: YOU ARE RESPONSIBLE FOR FIREARMS SAFETY

---

### **WARNING**

**FAILURE TO FOLLOW ANY OF THE FOLLOWING WARNINGS COULD RESULT IN SERIOUS INJURY OR DEATH.**

As a firearm owner, you accept a set of demanding responsibilities. How seriously you take these responsibilities can be the difference between life and death.

There is no excuse for careless or abusive handling of any firearm. At all times handle this firearm and all other firearms with intense respect for their power and potential danger.

Please read and understand all of the cautions, warnings, notices, proper handling procedures and instructions outlined in this owner's manual before using your new firearm.

### **1 ALWAYS KEEP THE MUZZLE OF YOUR FIREARM POINTED IN A SAFE DIRECTION EVEN THOUGH YOU ARE CERTAIN IT IS UNLOADED.**

Never point any firearm at anything you do not intend to shoot. Be extremely alert and aware of all persons and property within the range of your ammunition.

### **2 NEVER RELY TOTALLY ON YOUR FIREARM'S MECHANICAL "SAFETY" DEVICE. LIKE ANY MECHANICAL DEVICE, A "SAFETY" CAN SOMETIMES FAIL; IT CAN BE JARRED OR INADVERTENTLY MANIPULATED INTO AN UNSAFE CONDITION.**

The word "safety" describes a firearm's trigger block mechanism, sear block mechanism, hammer block mechanism or firing pin block mechanism.

Mechanical “safeties” are designed to place your firearm in a safer status, and no guarantee can be made that the firearm will not fire even if the “safety” is in the on safe position. Mechanical “safeties” merely aid safe gun handling and are no excuse for pointing your firearm’s muzzle in an unsafe direction. See “Operation of the “Safety” on page 9 for instructions on the operation of this firearm’s “safety.”

Remember, safe gun handling does not stop with your firearm’s mechanical “safety” devices, it starts there. Always treat this firearm with the respect due a loaded, ready-to-fire firearm.

Some firearms do not have a mechanical “safety”. Many target firearms, lever-action firearms and pistols do not have manual “safety” mechanisms. Therefore it is critical to read and understand the owner’s manual for every firearm which explains the safe operation of the firearm.

While it is a good idea to test your firearm’s mechanical “safety” periodically for proper function, never test the “safety” while your firearm is loaded or pointed in an unsafe direction.

- 3 WHENEVER YOU HANDLE ANY FIREARM, OR HAND IT TO SOMEONE, ALWAYS OPEN THE ACTION IMMEDIATELY AND VISUALLY CHECK THE FIREARM’S CHAMBER TO MAKE CERTAIN THAT THE FIREARM IS COMPLETELY UNLOADED.**

Make certain the firearm does not inadvertently contain any ammunition. Remember, merely removing the magazine does not mean the chamber is unloaded. Always keep the chamber empty and the “safety” in the on safe position unless shooting is imminent.

- 4 ALWAYS WEAR EAR AND EYE PROTECTION WHEN SHOOTING.**

Unprotected, repeated exposure to gunfire can cause hearing damage. Wear hearing protection (shooting earplugs or muffs) to guard against such damage.

Wear shooting glasses to protect your eyes from flying particles. Allow proper distance (eye relief) between a scope and your eye when firing a scoped pistol, rifle or shotgun. Do not use unorthodox shooting methods that could cause the rearward travel of the slide or bolt of a firearm to contact your eyes, face or hands. Always keep a safe distance between the muzzle of your firearm and any persons nearby, as muzzle blast, debris and ejecting shells could inflict serious injury.

Always wear eye protection when disassembling and cleaning any firearm to prevent the possibility of springs, spring-tensioned parts, solvents or other agents from contacting your eyes.

- 5 KEEP ALL FIREARMS UNLOADED DURING TRANSPORT, EVEN WHEN STORED IN A HOLSTER, GUN CASE, SCABBARD OR OTHER CONTAINER.**

**6 DROPPING OR JARRING A LOADED FIREARM CAN CAUSE ACCIDENTAL DISCHARGE.**

This can occur even with the “safety” in the on safe position. Be extremely careful while hunting or during any shooting activity to avoid dropping any firearm.

**7 HUNTING FROM ELEVATED SURFACES SUCH AS TREESTANDS IS DANGEROUS.**

Doing so may increase the risk of mishandling a firearm. The following rules should always be observed by you and those you hunt with. Always make certain that the stand being used is safe and stable. Always make certain that your firearm is unloaded when it is being taken up and down from the stand. Always make certain that your firearm is not dropped from the stand, or dropped while it is being taken up or down from the stand. Remember, a loaded firearm may discharge when dropped, even with the “safety” in the on safe position.

**8 STORE YOUR FIREARM AND AMMUNITION SEPARATELY, WELL BEYOND THE REACH OF CHILDREN.**

Take prudent safeguards to ensure your firearm does not become available to untrained, inexperienced or unwelcome hands. Store all firearms in secure, locked cases or a gun safe. Keep your firearm unloaded when not in use.

**9 BEWARE OF BARREL OBSTRUCTIONS.**

Mud, snow and an infinite variety of other objects may inadvertently lodge in a barrel bore. It only takes a small obstruction to cause dangerously increased pressures that can damage your firearm and cause serious injury to yourself and others.

**BEFORE CHECKING FOR A BARREL OBSTRUCTION, BE CERTAIN YOUR FIREARM IS COMPLETELY UNLOADED, THERE IS NOT A LIVE SHELL IN THE CHAMBER AND THE “SAFETY” IS IN THE ON SAFE POSITION.**

After assuring yourself that the firearm is completely unloaded, open the breech or action and look through the barrel to be sure it is clear of obstructions. If an obstruction is seen, no matter how small it may be, clean the bore with a cleaning rod and patch as described on pages 28-30 of this owner’s manual.

**10 BE ALERT TO THE SIGNS OF AMMUNITION MALFUNCTION. IF YOU DETECT AN OFF SOUND OR LIGHT RECOIL WHEN A SHELL IS FIRED, DO NOT LOAD ANOTHER SHELL INTO THE CHAMBER.**

If your firearm fails to fire, keep the muzzle pointed in a safe direction for a minimum of 30 seconds. Rotate the ejection area of the firearm away from you, carefully open the action and remove the shell from the chamber. If the primer is indented, the defective shell should be disposed of in a way that cannot cause harm. If the primer is not indented, your firearm

should be examined by a qualified gunsmith and the cause of the malfunction corrected before further use. Glance down the barrel to make sure that no obstructions remain in the barrel. Completely clear the barrel before loading and firing again. Failure to follow these instructions can cause extensive damage to your firearm and possible serious injury to yourself and others.

**11 NEVER INSERT A SHELL OF THE INCORRECT GAUGE INTO ANY FIREARM.**

The gauge of your firearm is marked on the barrel. Store all shells of different gauges in completely separate and well-marked containers. Never store shells of mixed gauges in a common container or in your pockets. See pages 14-15 for more information on the correct ammunition for your firearm.

**12 EXAMINE EVERY SHELL YOU PUT IN YOUR FIREARM.**

We assume no responsibility for the use of unsafe or improper firearm and ammunition combinations or damage or injury caused by damaged ammunition. It is your responsibility to read and heed all warnings in this owner's manual and on ammunition boxes. See page 14-15 for more information on the correct ammunition for your firearm.

**13 USE ONLY SAAMI APPROVED AMMUNITION.**

The barrel and action of this firearm have been made with substantial safety margins beyond the pressures developed by established American commercial loads.

Nevertheless, we can assume no liability for incidents which occur through the use of shells of nonstandard dimensions or which develop pressures in excess of commercially available ammunition which has been loaded in accordance with standards established by the Sporting Arms and Ammunition Manufacturers' Institute (SAAMI).

**14 DISCHARGING FIREARMS IN POORLY VENTILATED AREAS, CLEANING FIREARMS OR HANDLING AMMUNITION MAY RESULT IN EXPOSURE TO LEAD AND OTHER SUBSTANCES KNOWN TO CAUSE BIRTH DEFECTS, REPRODUCTIVE HARM AND OTHER SERIOUS PHYSICAL INJURY. HAVE ADEQUATE VENTILATION AT ALL TIMES. WASH HANDS THOROUGHLY AFTER EXPOSURE.**

**15 DO NOT SNAP THE FIRING PIN ON AN EMPTY CHAMBER; THE CHAMBER MAY NOT BE EMPTY!**

Treat every firearm with the respect due a loaded firearm, even though you are certain the firearm is unloaded.

**16 KEEP YOUR FINGERS AWAY FROM THE TRIGGER WHILE LOADING AND UNLOADING UNTIL SHOOTING IS IMMINENT.**

**17 BE SURE OF YOUR TARGET AND BACKSTOP, PARTICULARLY DURING LOW LIGHT PERIODS.**

Know the range of your ammunition. Never shoot at water or hard objects.

**18 ALWAYS UNLOAD YOUR FIREARM'S CHAMBER BEFORE CROSSING A FENCE, CLIMBING A TREE, JUMPING A DITCH OR NEGOTIATING OTHER OBSTACLES.**

Never place your firearm on or against a fence, tree, car or other similar object.

**19 BE DEFENSIVE AND ON GUARD AGAINST UNSAFE GUN HANDLING AROUND YOU AND OTHERS.**

Don't be timid when it comes to firearm safety. If you observe other shooters violating any of these safety precautions, politely suggest safer handling practices.

**20 BE CERTAIN YOUR FIREARM IS UNLOADED BEFORE CLEANING.**

Because so many firearm accidents occur when a firearm is being cleaned, special and extreme care should be taken to be sure your firearm is unloaded before disassembly, cleaning and reassembly.

Keep ammunition away from the cleaning location. Never test the mechanical function of any firearm with live ammunition.

**21 TEACH AND SUPERVISE FIREARMS SAFETY TO ALL MEMBERS OF YOUR FAMILY, ESPECIALLY TO CHILDREN AND NON-SHOOTERS.**

Closely supervise newcomers to the shooting sports. Encourage enrollment in hunting and shooting safety courses.

**22 NEVER DRINK ALCOHOLIC BEVERAGES OR TAKE ANY TYPE OF DRUGS BEFORE OR DURING SHOOTING.**

Your vision, motor skills and judgment could be dangerously impaired, making your gun handling unsafe to you and to others.

**23 READ AND HEED ALL WARNINGS IN THIS OWNER'S MANUAL, ON AMMUNITION BOXES AND WITH ALL ACCESSORIES THAT YOU INSTALL ON YOUR FIREARM.**

It is your responsibility to secure the most up-to-date information on the safe handling procedures of your Winchester firearm. We assume no liability for incidents which occur when unsafe or improper firearm accessories or ammunition combinations are used.

**24 PRACTICE PERIODIC MAINTENANCE, AVOID UNAUTHORIZED SERVICING.**

Your firearm is a mechanical device which will not last forever, and as such, is subject to wear and requires periodic inspection, adjustment and service. Winchester firearms should be serviced by a Winchester Repeating Arms Authorized Repair Center or by our Service Facility in Arnold, Missouri. We assume no responsibility for injuries suffered or caused by unauthorized servicing, alterations or modifications of Winchester firearms.

**25 DO NOT, UNDER ANY CIRCUMSTANCES, ALTER THE TRIGGER, "SAFETY" OR OTHER PARTS OF THE FIRING MECHANISM OF THIS OR ANY OTHER FIREARM EXCEPT AS OTHERWISE DESCRIBED IN THIS MANUAL.**

We reserve the right to refuse service on firearms that have been altered, added to or substantially changed. Removal of metal from the barrel, or modifications of the firing mechanism and/or operating parts may lead to a refusal of service on such firearms. You will be charged for parts and labor to return the firearm to original specifications prior to servicing your firearm.

With respect to **AFTERMARKET PARTS OR COMPONENTS** (including, for example, aftermarket trigger systems, barrels, muzzle brakes, suppressors, magazines, etc.), **USE AT YOUR OWN RISK**. Winchester firearms are designed and engineered to meet stringent safety standards. Winchester Repeating Arms is not responsible for personal injuries or property damage caused by alterations to a firearm. This includes the incorporation of aftermarket parts or components that may or may not satisfy Sporting Arms and Ammunition Manufacturers' Institute (SAAMI) standards (for example, an aftermarket trigger system may not satisfy SAAMI minimum trigger pull standards, etc.) or may create other dangerous conditions. These conditions may or may not be apparent to the user (for example, installing an aftermarket barrel may have the effect of altering

critical firearm dimensions, including headspace, and may create an unsafe firing condition, etc.). Aftermarket parts or components that do not satisfy SAAMI standards, or that could create other dangerous conditions, should not be used.

**FAILURE TO FOLLOW THIS WARNING COULD RESULT IN SERIOUS INJURY OR DEATH, AS WELL AS CAUSE DAMAGE TO YOUR FIREARM.**

## **BE CAREFUL!**

### GENERAL DESCRIPTION AND OPERATION

#### *GENERAL DESCRIPTION*

Every aspect of the Super X<sup>®</sup>4 is designed to produce unmatched reliability and superb handling, qualities that are demanded by serious hunters and shooters. The simple, self-adjusting Active Valve gas piston system makes the Super X4 the fastest cycling autoloader available. The alloy receiver balances weight between the hands with just enough barrel weight for a smooth swing. The acclaimed Invector-Plus™ interchangeable choke tube system provides superior shot patterns. As you learn about your new shotgun and begin shooting it, we're sure you'll agree its design sets new standards for reliability and handling.

Your shotgun is one of several different versions offered. The basic operating procedures are the same for all models. Where there are differences, they are pointed out in this owner's manual for your convenience.



**FIGURE 1**

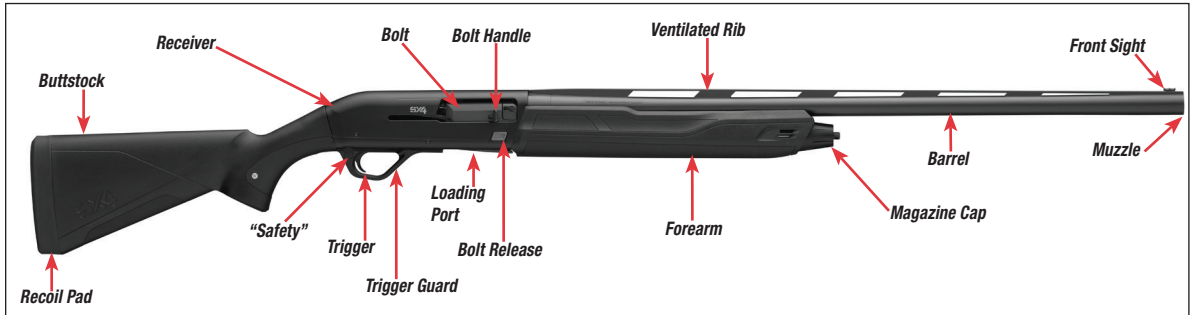

### GENERAL OPERATION

This shotgun is an autoloading design that allows you to fire follow-up shots by merely pulling the trigger. When you fire a shell, the Active Valve gas system moves a loaded shell from the magazine to the chamber where it is fired with a pull of the trigger. This can be repeated until the magazine is empty. A single shell can also be inserted into the chamber manually or moved from the loaded magazine by cycling the action with the bolt handle. With the magazine three-shot adaptor (plug) removed from the magazine and using 2¾" loads, the shotgun is capable of shooting five shots in rapid succession, one shot with each pull of the trigger. The short stroke and snug, gas-sealing fit of the gas piston limits the amount of combustion gases blown past the piston sleeve and into the receiver, keeping the inside of the receiver cleaner. This is an

exceptionally advanced design that offers reliable function from the gas system and easy disassembly for maintenance and cleaning. However, in order to keep your new shotgun in top condition and operating at its peak performance, you must read, understand and follow all of the instructions in this owner's manual.

Prior to using live ammunition, familiarize yourself thoroughly with the operating instructions in this owner's manual. Get accustomed to the feel of your new firearm and know the forces required to operate the action. Learn how to pull the trigger and, above all, know the location and operation of the "safety." Procedures for disassembly and operation of various components are outlined later in this owner's manual. Please read and study them thoroughly.

## NOMENCLATURE

In conventional firearm terminology the position and movement of firearm parts are described as they occur with the firearm horizontal and in the normal firing position: i.e., the muzzle is forward or in front; the buttstock is rearward or to the rear; the trigger is downward or underneath; the rib is upward or on top. For general parts nomenclature, refer to Figure 1, page 7. For specific parts names related to disassembly, refer to Figure 2, page 8.

The shotgun is also shown disassembled to the extent necessary in order to follow instructions contained in this book (Figure 2, page 8). Figure 4 (pages 10-11) covers the general features and benefits of the shotgun's design. Throughout this owner's manual the term "action" refers to the mechanism of this shotgun which loads and secures the shell in the chamber.

## SERIAL NUMBER

The serial number is located on the left side of the receiver, just above the trigger guard. Record the serial number at the front of this book for future reference.

## INITIAL CLEANING AND OILING

### **⚠WARNING**

**WEAR EYE PROTECTION WHEN ASSEMBLING AND DISASSEMBLING YOUR SHOTGUN TO PREVENT SPRINGS,**

FIGURE 2

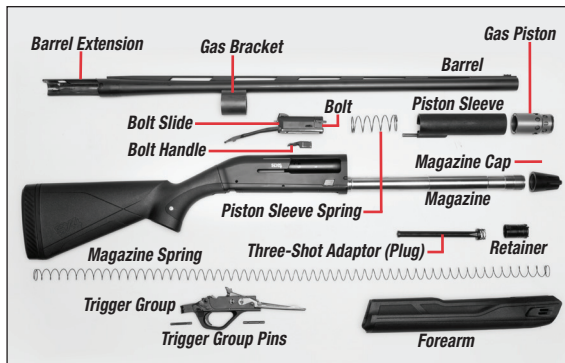

### **SPRING-LOADED PARTS, SOLVENTS OR OTHER AGENTS FROM CONTACTING YOUR EYES, RESULTING IN INJURY.**

Some metal parts of your new firearm have been coated at the factory with a rust preventative compound. Before using your firearm, clean the anti-rust compound from the inside of the barrel, receiver, bolt mechanism and the action/chamber areas. A high quality, lightweight gun oil should be used to remove this compound and to give your new firearm its first lubrication. Clean the barrel using a cleaning rod and patch as explained under "Cleaning and Maintenance Suggestions" found on pages 28-30 in this owner's manual. Before beginning assembly of your firearm you should first wipe the mechanism clean and apply a few drops of quality oil on the indicated surfaces (Figure 3, page 9). Avoid applying too much oil. Only a light film is

**FIGURE 3**

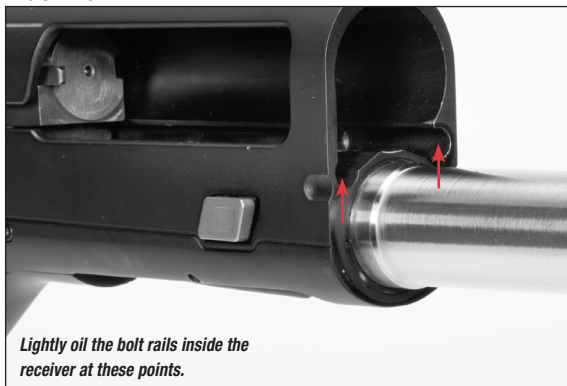

necessary. Excessive oil should be wiped off, especially in cold weather.

### OPERATION OF THE “SAFETY”

#### **▲WARNING**

**ALWAYS KEEP THE “SAFETY” IN THE ON SAFE POSITION UNLESS SHOOTING IS IMMINENT. ALWAYS KEEP THE MUZZLE POINTED IN A SAFE DIRECTION. FAILURE TO FOLLOW THESE WARNINGS COULD RESULT IN SERIOUS INJURY OR DEATH.**

The cross bolt “safety” is designed to prevent the trigger from being pulled when in the on safe position. The

“safety” is located at the rear of the trigger guard. In the off safe position, a red warning band is visible on the “safety” button on the left side of the trigger guard. It is essential that you become very familiar with the feel, look and operation of the “safety” on this shotgun before attempting to load and shoot.

The “safety” on this shotgun is reversible for right- or left-handed operation. It comes from the factory in the right-handed position. Verify the installation of your firearm’s “safety.” Instructions in this owner’s manual are for the “safety” installed in the right-handed position.

To place the firearm on safe, press the “safety” button to the right (Figure 5, page 12). To move the “safety” to the off safe or fire position, press the “safety” button to the left. This exposes the red warning band on the “safety” button (Figure 6, page 12).

With the “safety” in the on safe position the trigger and hammer are blocked and the shotgun cannot be fired. In the off safe position, if your firearm is loaded with a shell in the chamber, the chambered shell can be fired by simply pulling the trigger.

#### **▲WARNING**

**DO NOT DEPEND ON THE RED COLOR ALONE TO INDICATE YOUR FIREARM’S “SAFETY” STATUS. TIME, EXPOSURE TO THE ELEMENTS AND THE ABRASIVE ACTION OF CLEANING AGENTS CAN ERASE IT. FAILURE TO FOLLOW THIS WARNING COULD RESULT IN SERIOUS INJURY OR DEATH.**

(Continued on page 12.)

FIGURE 4

**SX4™**

SHOTGUN FEATURES



*The entire bolt assembly removes easily for thorough cleaning. This is a firearm designed for extreme reliability under real-world, adverse hunting conditions.*

*Back-Bored Technology creates the ideal bore diameter, providing improved pattern performance and shot velocity.*

*The advanced aluminum alloy receiver offers the strength of steel and exceptional between-the-hands balance.*

*For optimum shooting comfort, SX4 shotguns feature a soft Inflex Technology recoil pad that uses directional deflection to pull the stock down and away from your face.*

*The large "safety" button offers excellent convenience, even with gloved fingers. It is reversible for left-handed shooters.*

*The trigger assembly uses a durable two-pin system for easy maintenance and cleaning.*

*Oversized bolt handle and bolt release for faster, easier operation.*

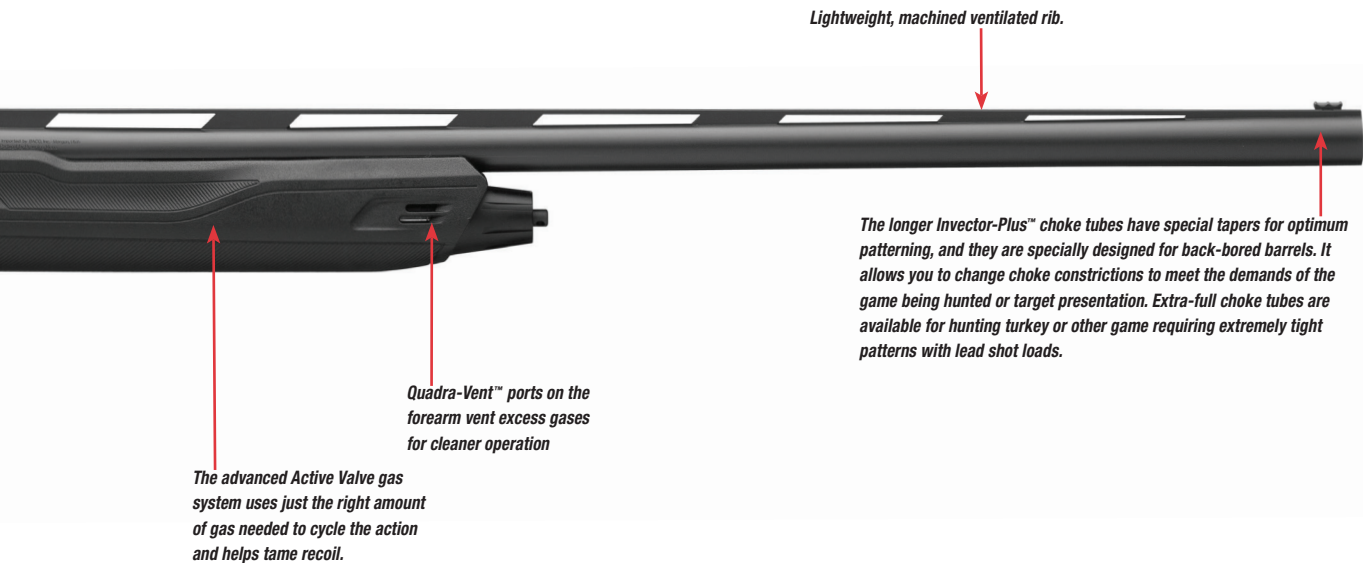

FIGURE 5



FIGURE 6



FIGURE 7



1. Take the receiver in hand. Lock the bolt rearward by pulling the bolt handle fully to the rear.

## ASSEMBLY

### **⚠WARNING**

**ALWAYS KEEP THE MUZZLE POINTED IN A SAFE DIRECTION. BEFORE STARTING ASSEMBLY PROCEDURES, VISUALLY INSPECT THE CHAMBER TO BE ABSOLUTELY CERTAIN THE FIREARM IS COMPLETELY UNLOADED. PLACE THE "SAFETY" IN THE ON SAFE POSITION. FAILURE TO FOLLOW THIS WARNING COULD RESULT IN SERIOUS INJURY OR DEATH.**

The Super X®4 shotgun is delivered in the box with the barrel removed and the forearm attached to the magazine tube.

### **NOTICE**

**NEVER ALLOW THE ACTION TO SLAM CLOSED BY PRESSING THE CARRIER RELEASE BUTTON WITHOUT THE BARREL INSTALLED. IF THE BOLT IS RELEASED FORWARD WITH THE BARREL REMOVED, THE BOLT HANDLE WILL HIT THE RECEIVER AND CAUSE DAMAGE.**

2. Remove the forearm from the magazine tube by unscrewing the magazine cap and sliding the forearm forward, off the magazine tube.

**FIGURE 8**

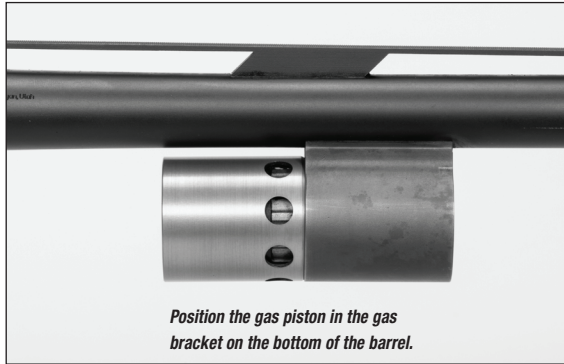

**NOTICE**

**DO NOT SQUEEZE HARD ON THE OPEN REAR END OF A WOOD FOREARM. TOO MUCH PRESSURE COULD CAUSE THE WOOD TO SPLIT.**

3. The components of the gas system: The piston sleeve, piston sleeve spring and gas piston remain in place and do not need to be removed except for cleaning. If these components have been removed, reinstall them as explained below. Otherwise, proceed to step 7.
4. Slide the piston sleeve spring and piston sleeve (push rod end first) onto the magazine tube.
  - The push rod on 12 gauge models goes into the slot on the left side of the receiver (Figure 7, page 12).

**FIGURE 9**

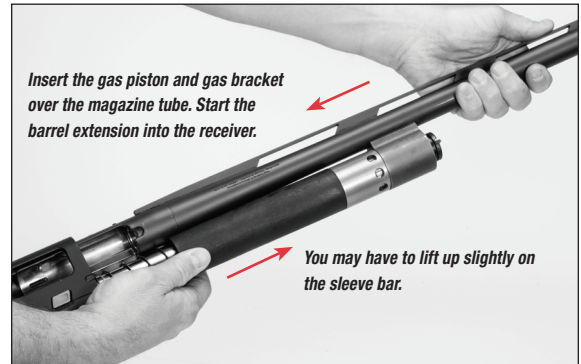

- The push rod on 20 gauge models goes into the slot on the right side of the receiver.
- Make sure the piston sleeve spring is properly positioned in the piston sleeve.
5. Slide the gas piston into the gas bracket (Figure 8, page 13).
  6. Align the gas bracket and gas piston over the magazine tube (Figure 9, page 13). Slide the gas bracket and gas piston over the magazine tube. The barrel extension should slip solidly down into the receiver. Make sure the push rod moves freely in its slot in the receiver.
  7. Replace the forearm by sliding it onto the magazine tube and over the gas bracket so it seats securely.

Install the magazine cap finger tight. Open and close the action several times and retighten the magazine cap to ensure a proper seal.

## DISASSEMBLY

---

### **⚠WARNING**

**ALWAYS KEEP THE MUZZLE POINTED IN A SAFE DIRECTION. BEFORE STARTING DISASSEMBLY PROCEDURES, OPEN THE ACTION AND VISUALLY INSPECT THE CHAMBER TO BE ABSOLUTELY CERTAIN THE FIREARM IS COMPLETELY UNLOADED. PLACE THE "SAFETY" IN THE ON SAFE POSITION. FAILURE TO FOLLOW THIS WARNING COULD RESULT IN SERIOUS INJURY OR DEATH.**

1. Unscrew the magazine cap and remove it.
2. Remove the forearm by sliding it forward off the magazine tube.
3. For cleaning, remove the barrel, gas piston, piston sleeve and piston sleeve spring by sliding them forward off the magazine tube. See "Cleaning and Maintenance Suggestions" on pages 28-30 for cleaning procedures.

If you are disassembling for storage, return the piston sleeve spring, piston sleeve and piston onto the magazine tube. Reinstall the forearm over the magazine tube and screw on the magazine cap. You

will then have two compact units: 1) The barrel 2) The action with the stock and forearm.

### **NOTICE**

**AFTER THE BARREL HAS BEEN REMOVED, LEAVE THE BOLT IN THE REARWARD POSITION. DO NOT PRESS THE BOLT RELEASE BUTTON. IF THE BOLT IS RELEASED FORWARD WITH THE BARREL REMOVED, THE BOLT HANDLE WILL STRIKE THE RECEIVER, CAUSING DAMAGE.**

## AMMUNITION

---

### **⚠WARNING**

**DISCHARGING FIREARMS IN POORLY VENTILATED AREAS, CLEANING FIREARMS OR HANDLING AMMUNITION MAY RESULT IN EXPOSURE TO LEAD AND OTHER SUBSTANCES KNOWN TO CAUSE BIRTH DEFECTS, REPRODUCTIVE HARM AND OTHER SERIOUS PHYSICAL INJURY. HAVE ADEQUATE VENTILATION AT ALL TIMES. WASH HANDS THOROUGHLY AFTER EXPOSURE.**

**USE ONLY SHELLS OF THE CORRECT GAUGE AND LENGTH. THE GAUGE AND LENGTH OF THE CHAMBER IS INSCRIBED ON THE SIDE OF THE BARREL. DO NOT USE AMMUNITION OTHER THAN WHAT IS INSCRIBED ON THE SIDE OF THE BARREL. EXAMINE EVERY SHELL YOU PUT**



**IN YOUR SHOTGUN. FAILURE TO FOLLOW THIS WARNING COULD RESULT IN SERIOUS INJURY OR DEATH AND CAUSE DAMAGE TO YOUR SHOTGUN.**

**USE SHELLS OF THE CORRECT LENGTH. DO NOT USE 3" OR 3½" SHELLS IN A BARREL WITH A 2¾" OR 2½" CHAMBER, OR 3½" SHELLS IN A BARREL WITH A 3" CHAMBER. DOING SO CAN RESULT IN A BUILDUP OF DANGEROUSLY HIGH PRESSURES. FAILURE TO FOLLOW THIS WARNING COULD RESULT IN SERIOUS INJURY OR DEATH AND CAUSE DAMAGE TO YOUR SHOTGUN.**

**DO NOT PUT A 16 GAUGE SHELL OR A 20 GAUGE SHELL IN A 12 GAUGE SHOTGUN. DO NOT PUT A 28 GAUGE SHELL IN A 20 GAUGE SHOTGUN. DO NOT PUT A .410 BORE SHELL IN A 28 GAUGE SHOTGUN. NEVER PUT METALLIC SHELLS OF ANY KIND IN A SHOTGUN. SPECIFICALLY, NEVER PUT CENTERFIRE RIFLE OR PISTOL CARTRIDGES IN A SHOTGUN CHAMBERED FOR .410 BORE. FAILURE TO FOLLOW THIS WARNING COULD RESULT IN SERIOUS INJURY OR DEATH AND CAUSE DAMAGE TO YOUR SHOTGUN.**

The most certain way to bulge or rupture a shotgun barrel is to load a smaller gauge shell into a larger gauge chamber. The smaller gauge shell will not fall completely through the barrel; its rim is caught by the front of a larger gauge chamber or at the larger gauge's choke. Your shotgun will misfire (with the chamber appearing to be empty). It is then possible to load the correct gauge shell behind the smaller gauge shell. If the shotgun is then

fired, the result will be a so-called "12-16, 12-20, 20-28 or 28-.410 burst" which can cause extensive damage to your shotgun and possible serious injury to you and others.

We can assume no responsibility for incidents which occur through the use of shells of nonstandard dimension or those developing pressures in excess of SAAMI established standards.

There are three basic versions of this shotgun. This information can be found inscribed on the barrel. The barrel can safely shoot both lead and steel shot. Special rifled choke tubes and rifled barrels are designed for shooting sabot-type slugs. Winchester ammunition is always an excellent choice for your shotgun, delivering unmatched performance and dependability.

- 12 gauge, 3½" chamber — These models have a 3½" chamber designed to shoot factory 12 gauge loads including 2¾", 3" and 3½" (1⅛ oz. to 2¼ oz.) field loads. (They are not designed to shoot the lightest factory ⅞ oz. and 1 oz. loads.)
- 12 gauge, 3" chamber — These models have a 3" chamber designed to shoot factory 12 gauge loads including 2¾" and 3" (1 oz. to 2 oz.) field loads. (They are not designed to shoot the lightest factory ⅞ oz. and 1 oz. target loads or any 3½" shells.)
- 20 gauge, 3" chamber — These models have a 3" chamber designed to shoot factory 20 gauge loads including 2¾" and 3" (⅞ oz. to 1½ oz.) field loads. (They are not designed to shoot the lightest factory ⅞ oz. and 1 oz. target loads.)

## MAGAZINE CAPACITY

---

With the magazine three-shot adaptor (plug) removed, Super X®4 3" shotguns (12 and 20 gauge) will hold four 2¾" or three 3" shells in the magazine. Super X4 3½" shotguns will hold four 2¾" shells, or three 3" or 3½" shells in the magazine. With the magazine three-shot adaptor (plug) installed magazine capacity is limited to two shells in the magazine.

Remember, "total" capacity includes an additional shell in the chamber in addition to a full magazine.

It is extremely important that you know the magazine capacity of your shotgun. Under appropriate circumstances, at a range or other suitable shooting location, load your magazine to full capacity and make note of the number of shells.

IMPORTANT: Because 3" and 3½" shotguns can handle mixed shells of different lengths, total capacity may be affected.

## THREE-SHOT ADAPTOR (PLUG)

---

### **⚠WARNING**

**ALWAYS KEEP THE MUZZLE POINTED IN A SAFE DIRECTION. BEFORE REMOVING OR INSTALLING THE THREE-SHOT ADAPTOR, COMPLETELY UNLOAD THE SHOTGUN. OPEN THE ACTION AND VISUALLY INSPECT THE CHAMBER, FEED MECHANISM AND MAGAZINE TO BE ABSOLUTELY CERTAIN THE FIREARM IS**

**COMPLETELY UNLOADED. PLACE THE "SAFETY" IN THE ON SAFE POSITION. FAILURE TO FOLLOW THIS WARNING COULD RESULT IN SERIOUS INJURY OR DEATH.**

**WEAR EYE PROTECTION WHEN REMOVING OR INSTALLING THE THREE-SHOT ADAPTOR TO PREVENT SPRINGS, SPRING-LOADED PARTS, SOLVENTS OR OTHER AGENTS FROM CONTACTING YOUR EYES, RESULTING IN INJURY.**

The Super X®4 shotgun is delivered with the magazine three-shot adaptor (plug) installed in the magazine, limiting magazine capacity to two shells in compliance with federal migratory bird regulations. If you do not wish to be limited to three shots, when it is not required by law, you can remove (or reinstall) the three-shot adaptor as follows:

### REMOVING THE THREE-SHOT ADAPTOR (PLUG)

1. Unscrew the magazine cap and remove it, the forearm, barrel and gas piston.
2. The magazine three-shot adaptor is located underneath the magazine spring retainer located in the forward end of the magazine tube. To remove the magazine spring retainer, use a flat-blade screwdriver to depress the magazine spring retainer tab, located in the window on the magazine tube while keeping your hand on the magazine spring retainer (Figure 10, page 17). Slowly remove the magazine spring retainer

**FIGURE 10**



as it is under pressure from the magazine spring (Figure 11, page 17). Remove the magazine three-shot adaptor (Figure 12, page 17).

3. Compress the magazine spring back into the magazine tube and replace the magazine spring retainer. Make sure the magazine spring retainer tab is locked in place in the slot in the magazine tube.
4. Reinstall the gas piston, barrel, forearm and magazine cap.

#### **INSTALLING THE THREE-SHOT ADAPTOR (PLUG)**

If you need to install the magazine three-shot adaptor (plug) to limit your shotgun magazine to three shells, again perform the following operation:

**FIGURE 11**



**FIGURE 12**



1. Unscrew the magazine cap and remove it, the forearm, barrel and gas piston.
2. Carefully remove the magazine spring retainer as explained previously, maintaining control of the magazine spring.
3. Insert the three-shot adaptor (plug) into the magazine. Use the three-shot adaptor to force the magazine spring into the magazine until the base of the three-shot adaptor is level with the end of the magazine tube.
4. Replace the magazine spring retainer. Make sure the magazine spring retainer tab is locked in place in the slot in the magazine tube.
5. Reinstall the gas piston, barrel, forearm and magazine cap.

## LOADING

---

### **⚠WARNING**

**WHEN LOADING YOUR SHOTGUN ALWAYS KEEP THE MUZZLE POINTED IN A SAFE DIRECTION, ALWAYS PLACE THE “SAFETY” IN THE ON SAFE POSITION AND KEEP YOUR FINGERS AWAY FROM THE TRIGGER. FAILURE TO FOLLOW THESE WARNINGS COULD RESULT IN SERIOUS INJURY OR DEATH.**

**TO AVOID ACCIDENTAL DISCHARGE, DO NOT CARRY YOUR SHOTGUN WITH A SHELL IN THE CHAMBER. WHEN**

**FIRING IS NO LONGER IMMINENT, MAKE SURE THE “SAFETY” IS IN THE ON SAFE POSITION AND UNLOAD THE CHAMBER. FAILURE TO FOLLOW THESE WARNINGS COULD RESULT IN SERIOUS INJURY OR DEATH.**

There are two methods used to load a shell into the chamber of the 12 gauge Super X4 shotgun: Loading through the ejection port and loading from the magazine.

20 gauge models may be loaded by these two methods and also loaded with the Speed Load feature. See page 20 for additional details.

### LOADING THE MAGAZINE

1. Pull the bolt handle to the rear until the bolt locks in the open position. Visually inspect the chamber, feed mechanism and magazine to make sure they are unloaded and clear of any obstructions.
2. Close the bolt by pressing the bolt release button.
3. Insert a shell of the proper gauge and length through the loading port at the bottom of the receiver up into the magazine, using your thumb to position it fully forward in the magazine tube (Figure 13, page 19). Make certain the rim of the shell engages the shell stop and is held fully inside the magazine tube. It will make an audible click when fully inserted.
4. If desired, continue loading the magazine until it is full.

**FIGURE 13**



#### **LOADING THE CHAMBER MANUALLY FROM THE MAGAZINE**

1. With the bolt closed, depress the carrier with the front of the shell and, using your thumb, push the shell into the magazine until the shell is held in place by the shell stop.
2. If desired, continue to load the magazine, as explained above, to full capacity.
3. If firing is imminent, a shell can now be moved from the magazine to the chamber by pulling back fully on the bolt handle and releasing it forward. A shell will be fed automatically from the magazine to the

chamber as the bolt closes. Another shell can then be inserted into the magazine to load to full capacity.

#### **⚠WARNING**

**THE SHOTGUN IS NOW READY TO FIRE BY SIMPLY MOVING THE “SAFETY” TO THE OFF SAFE POSITION AND PULLING THE TRIGGER.**

#### **LOADING THE CHAMBER THROUGH THE EJECTION PORT**

1. Pull the bolt handle to the rear until the bolt locks in the open position. Visually inspect the chamber, feed mechanism and magazine to make sure they are clear of any obstructions.
2. Insert a shell of the proper gauge and length through the ejection port into the open breech (Figure 14, page 20).
3. Press the bolt release button to deliver the shell into the chamber. The chamber is now loaded.

#### **⚠WARNING**

**KEEP YOUR FINGERS CLEAR OF THE EJECTION PORT WHENEVER CLOSING THE ACTION WITH THE BOLT RELEASE BUTTON. FAILURE TO FOLLOW THIS WARNING COULD RESULT IN INJURY.**

4. With a shell in the chamber, you may load the magazine to full capacity. To load the magazine, insert a shell of the proper gauge and length through the

FIGURE 14

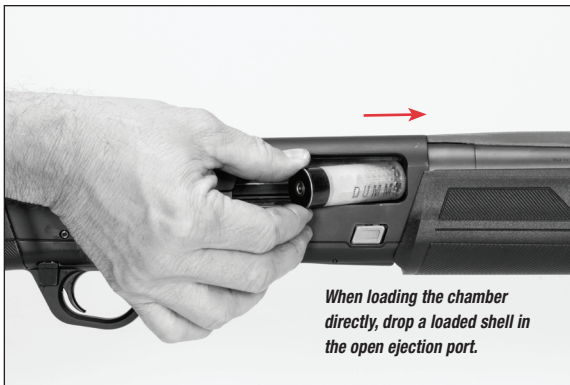

loading port at the bottom of the receiver up into the magazine, using your thumb to position it fully forward in the magazine tube. Make sure the rim of the shell engages the shell stop and is held fully inside the magazine tube. It will make an audible click when fully inserted.

**▲WARNING**

**THE SHOTGUN IS NOW READY TO FIRE BY SIMPLY MOVING THE "SAFETY" TO THE OFF SAFE POSITION AND PULLING THE TRIGGER.**

**SPEED LOADING (20 GAUGE ONLY)**

The Speed Load function of the Super X® 4 20 gauge models makes loading the chamber fast and convenient. With the bolt open and the magazine empty, the first shell inserted into the magazine will be instantly loaded into the chamber. To use this feature, perform the following operation.

1. With the magazine empty, lock the bolt to the rear in the open position
2. Insert a shell into the magazine. The shell will be automatically cycled from the magazine to the chamber.

**▲WARNING**

**KEEP YOUR FINGERS CLEAR OF THE EJECTION PORT WHEN LOADING THE SHOTGUN USING THE SPEED LOADING PROCEDURE. FAILURE TO FOLLOW THIS WARNING COULD RESULT IN INJURY.**

3. If desired, load the magazine to full capacity by inserting a shell of the proper gauge and length through the loading port at the bottom of the receiver up into the magazine, using your thumb to position it fully forward in the magazine tube (Figure 13, page 19). Make sure the rim of the shell engages the shell stop and is held fully inside the magazine tube. It will make an audible click when fully inserted.

**⚠WARNING**

**THE SHOTGUN IS NOW READY TO FIRE BY SIMPLY MOVING THE “SAFETY” TO THE OFF SAFE POSITION AND PULLING THE TRIGGER.**

## **FIRING**

---

**⚠WARNING**

**NEVER LOAD A SHELL INTO THE CHAMBER OR PLACE THE “SAFETY” IN THE OFF SAFE POSITION UNLESS SHOOTING IS IMMINENT. ALWAYS KEEP THE MUZZLE POINTED IN A SAFE DIRECTION. FAILURE TO FOLLOW THESE WARNINGS COULD RESULT IN SERIOUS INJURY OR DEATH.**

1. Place the “safety” in the on safe position and load a shell into the chamber as explained previously.
2. With a shell in the chamber, you need only move the “safety” to the off safe position to fire the shotgun.
3. When ready to fire, move the “safety” into the off safe position, take aim and squeeze the trigger.

After a shell is fired, the gas-operated system ejects the fired shell and picks up a loaded shell from the magazine and automatically chambers it.

You may continue to fire the shotgun until the magazine is empty by pulling the trigger to fire each shell. After the last shell is fired, the breech of the shotgun remains open, with the bolt locked to the rear. This allows convenient and fast reloading.

If you are done shooting, leave the bolt locked to the rear, with the breech in the open position so that you may visually inspect the chamber, bore, carrier and magazine to be sure they contain no shells.

**⚠WARNING**

**AFTER FIRING, OR WHEN SHOOTING IS NO LONGER IMMINENT, IMMEDIATELY PLACE THE “SAFETY” IN THE ON SAFE POSITION.**

**FAILURE TO FOLLOW THESE WARNINGS COULD RESULT IN SERIOUS INJURY OR DEATH.**

**EVEN WITH THE BOLT LOCKED OPEN AFTER SHOOTING, DO NOT ASSUME THE SHOTGUN IS UNLOADED. ALWAYS INSPECT THE CHAMBER, FEED MECHANISM AND MAGAZINE TO BE CERTAIN THE SHOTGUN IS COMPLETELY UNLOADED. FAILURE TO FOLLOW THESE WARNINGS COULD RESULT IN SERIOUS INJURY OR DEATH.**

## UNLOADING

---

### **▲WARNING**

**WHEN UNLOADING YOUR SHOTGUN ALWAYS PLACE THE “SAFETY” IN THE ON SAFE POSITION. KEEP THE MUZZLE POINTED IN A SAFE DIRECTION AND YOUR FINGERS AWAY FROM THE TRIGGER. FAILURE TO FOLLOW THESE WARNINGS COULD RESULT IN SERIOUS INJURY OR DEATH.**

**ALWAYS INSPECT THE CHAMBER, FEED MECHANISM AND MAGAZINE CAREFULLY AFTER UNLOADING TO BE SURE ALL LIVE SHELLS ARE CLEARED FROM THE FIREARM.**

1. Grasp the bolt handle and cycle the action until all shells are transferred from the magazine to the chamber and then ejected. Take care to avoid damaging shells. Avoid letting them fall to the ground.
2. When the last shell in the magazine has been cycled through the chamber and out the ejection port, the bolt will lock rearward. The bolt will also lock rearward when cycled with an empty magazine.
3. Visually inspect the chamber, feed mechanism and magazine to assure there are no shells remaining.

## INTERCHANGEABLE CHOKE TUBE SYSTEM

---

### **▲WARNING**

**NEVER ATTEMPT TO REMOVE OR INSTALL A CHOKE TUBE IN A LOADED FIREARM. WHENEVER REMOVING OR INSTALLING A CHOKE TUBE IN A SHOTGUN ALWAYS KEEP THE MUZZLE POINTED IN A SAFE DIRECTION. OPEN THE ACTION AND MAKE ABSOLUTELY CERTAIN THE SHOTGUN IS COMPLETELY UNLOADED, ALWAYS PLACE THE “SAFETY” IN THE ON SAFE POSITION AND KEEP YOUR FINGERS AWAY FROM THE TRIGGER. FAILURE TO FOLLOW THESE WARNINGS COULD RESULT IN SERIOUS INJURY OR DEATH.**

### **▲CAUTION**

**INVECTOR-PLUS, STANDARD INVECTOR AND WINCHOKE CHOKE TUBES ARE NOT INTERCHANGEABLE. DO NOT USE INVECTOR-PLUS, STANDARD INVECTOR OR WINCHOKE CHOKE TUBES IN ANY SHOTGUN BARREL NOT SUPPLIED BY WINCHESTER REPEATING ARMS.**

**DO NOT USE ANY OTHER CHOKING DEVICE IN ANY SHOTGUN BARREL SUPPLIED BY WINCHESTER REPEATING ARMS.**

**USE ONLY THE APPROPRIATE GAUGE AND TYPE OF CHOKE TUBE, MARKED INVECTOR-PLUS, STANDARD INVECTOR OR WINCHOKE, IN THIS SHOTGUN. DO NOT FIRE THIS SHOTGUN WITHOUT THE CORRECT CHOKE**



**TUBE INSTALLED. DAMAGE MAY RESULT TO THE THREADS INSIDE THE BARREL.**

**FAILURE TO FOLLOW THIS INFORMATION COULD RESULT IN DAMAGE TO YOUR SHOTGUN OR POSSIBLE INJURY.**

**NOTICE**

**USE ONLY THE CHOKE TUBE WRENCH SUPPLIED WITH YOUR SHOTGUN TO INSTALL AND REMOVE CHOKE TUBES. USING ANY OTHER WRENCH MAY DAMAGE THE THREADS IN THE BARREL.**

All Super X<sup>®</sup>4 shotgun barrels are threaded to accept the Invector-Plus<sup>™</sup> choke system. Standard Invector, WinChoke and Invector-Plus tubes are not interchangeable. Confirm the choke system of your shotgun by looking on the right side of the barrel where the specifications are inscribed, where the choke markings are normally located.

The constriction of each choke tube is indicated twice on the choke tube: On the side of the tube, and indicated with a “notch” code on the top rim of the tube. The included choke tube wrench is used to remove and install choke tubes.

Some target shotguns include premium extended choke tubes. The constriction of premium choke tubes is indicated twice on the choke tube: On the side of the tube, and indicated with an abbreviation in the colored band. The constriction of flush fit choke tubes is

indicated twice on the choke tube: On the side of the tube, and indicated with a “notch” code on the top rim of the tube. The included choke tube wrench is used to remove and install extended choke tubes.

Choke tubes are compatible with factory ammunition that has been loaded in compliance with SAAMI specifications, including magnum lead and steel shot loads, sabots and shotgun slug loads.

Replacement and additional tubes and wrenches are available from your Winchester Repeating Arms dealer, or by contacting the Winchester Repeating Arms Customer Service Department. See page 37 for contact information.

**CHOKE TUBE SELECTION**

To help you choose the correct choke tube for each hunting and shooting situation, Invector choke tubes are inscribed on the side with the patterns they produce with both lead and steel shot. Each Invector tube also has notches in the top rim of the tube (Figure 15, page 24). These notches are a code to allow you to determine the choke designation while the tube is installed. Rim notches refer specifically to lead shot. Use the charts on this page to cross-reference from lead to steel, and determine the appropriate tubes for your ammunition and hunting/shooting situation.

Several choke tubes are supplied with your shotgun. The choke tubes listed are also available as accessories. Remember, WinChoke, Standard Invector and Invector-Plus tubes are not interchangeable. Before

**FIGURE 15**

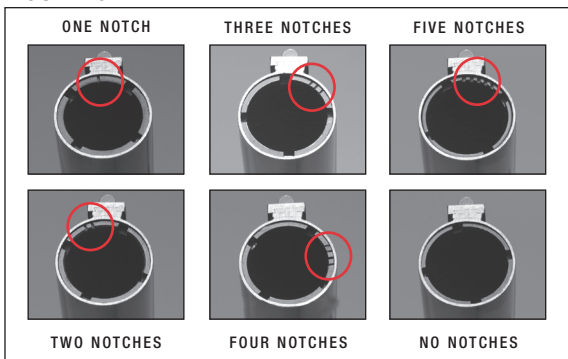

RIM NOTCHES	PATTERN WITH LEAD SHOT	PATTERN WITH STEEL SHOT
EXTENDED**	X-FULL TURKEY	**
I	FULL	*
II	IMP. MODIFIED	FULL <sup>1</sup>
III	MODIFIED	FULL <sup>1</sup>
IIII	IMP. CYLINDER	MODIFIED
IIIII	SKEET	IMP. CYLINDER
NO NOTCHES	CYLINDER	CYLINDER

\* Not for use with steel shot. Using an over-tight choke constriction with steel shot will result in an ineffective “blown” pattern.

\*\*Extra Full Turkey, extended with ports. Do not use with steel shot.

<sup>1</sup> When more than one choke tube is listed for a given steel shot pattern, use the more open choke listed for high velocity, larger shot size steel loads.

removing or installing tubes, or reading the rim notch code, make sure your shotgun is completely unloaded and the “safety” is in the on safe position.

#### **CHOKE TUBE REMOVAL**

1. Place the “safety” in the on safe position. Always make sure the shotgun is completely unloaded. Always keep the muzzle pointed in a safe direction.
2. Use the choke tube wrench to loosen the tube, turning it counterclockwise. Finger-twist the tube the rest of the way out of the barrel.

#### **CHOKE TUBE INSTALLATION**

1. Place the “safety” in the on safe position. Always make sure the shotgun is completely unloaded. Always keep the muzzle pointed in a safe direction.
2. Before installing a tube, check the internal choke tube threads in the muzzle, as well as the threads on the choke tube to be sure they are clean. Lightly oil the threads with a high-quality, lightweight gun oil.

#### **NOTICE**

**FAILURE TO CLEAN AND OIL THE THREADS ON THE CHOKE TUBE COULD RESULT IN THE CHOKE TUBE SEIZING IN THE BARREL.**

3. Using your fingers, screw the appropriate tube into the muzzle of the barrel, tapered end first, notched end outward. When it becomes finger-tight, use the included choke tube wrench to firmly seat the tube.

### **NOTICE**

**THE CHOKE TUBES SHOULD BE PERIODICALLY CHECKED TO ASSURE THEY ARE TIGHT AND FIRMLY SEATED. BEFORE CHECKING, FOLLOW ALL CHOKE TUBE REMOVAL AND INSTALLATION "SAFETY" GUIDELINES PREVIOUSLY OUTLINED.**

### *SCOPE MOUNTING INSTRUCTIONS*

---

#### **⚠WARNING**

**BEFORE MOUNTING A SCOPE, SIGHT OR OTHER ACCESSORIES TO YOUR SHOTGUN, PLACE THE "SAFETY" IN THE ON SAFE POSITION. OPEN THE ACTION AND MAKE CERTAIN YOUR SHOTGUN IS COMPLETELY UNLOADED. KEEP THE MUZZLE POINTED IN A SAFE DIRECTION. FAILURE TO FOLLOW THESE WARNINGS COULD RESULT IN SERIOUS INJURY OR DEATH.**

Some Super X\*4 shotguns are designed to accept a scope or other optical sight; usually these are turkey and deer models. The top of the receiver on some of these models is drilled and tapped for scope bases. Other models are equipped with a cantilever scope base. If your shotgun has a cantilever mount, follow the mounting instructions supplied with your scope rings and/or scope. If your shotgun's receiver is drilled and tapped for scope mounts, four holes (in line, in pairs on top of the receiver) will be visible. They are fitted with filler screws. If your receiver is drilled and tapped you must adhere to the following:

### **NOTICE**

**YOUR WINCHESTER SHOTGUN IS DRILLED AND TAPPED FOR THE MOUNTING OF BASES AND RINGS TO ACCOMMODATE AN APPROPRIATE SCOPE OR SIGHT. ALWAYS USE THE CORRECT BASES FOR THIS SHOTGUN WITH THE APPROPRIATE LENGTH SCREWS WHICH ARE AT LEAST  $1\frac{1}{32}$ " IN LENGTH.**

1. Open the action and place your shotgun on a table or other safe/secure location. Protect the finish with rags or other padding.
2. You should have two Super X\*4 compatible bases and four screws of at least  $1\frac{1}{32}$ " in length. Make sure your bases are compatible with your shotgun.
3. Clean all oil, grease or dirt from the receiver top and from the scope base parts.
4. Position your shotgun in the upright position with the top of the receiver upward.
5. Remove all four filler screws from the top of the receiver using a very small, thin-bladed gunsmithing-type screwdriver.
6. Pre-position the bases on the receiver top to determine the best orientation of the bases. Most bases have transverse grooves cut into them that are offset from the middle. These are the grooves that the crossbolts in your scope rings will pass through. The grooves are offset to allow you to position the bases to fit the design/length of your scope and the placement

of the scope front to back for proper eye relief. Place both grooves to the rear, both to the front, or one in each direction, depending on your scope and desired position.

7. Once you know which configuration you will use, insert the screws through the bases and screw them into the receiver top using the correct wrench or screwdriver (usually a  $\frac{3}{32}$ " hex wrench). You must use screws which are at least  $1\frac{1}{2}$ " in length to ensure proper thread engagement.

Many gunsmiths find it helpful to use a drop of serviceable thread locking compound to assure the screws stay tight. Make sure the compound does not get into the action. Be careful to assure that the threads of each screw engage properly in the threads in the receiver to prevent stripping the threads in the alloy receiver.

8. Tighten the screws snugly, but do not overtighten.
9. Mount your scope rings and scope as outlined in the instructions supplied with your scope rings and/or scope. Always make sure you have the proper eye relief. Always make sure that the saddle crossbolts and the cap bolts on the rings are fully tightened before using your shotgun.

## EXTRA BARRELS

### **▲WARNING**

**BEFORE INSTALLING ACCESSORY BARRELS ON YOUR SHOTGUN, READ THE FOLLOWING GUIDELINES TO ENSURE THE BARREL/SHOTGUN COMBINATION IS SAFE. PLACE THE "SAFETY" IN THE ON SAFE POSITION. OPEN THE ACTION AND MAKE CERTAIN YOUR SHOTGUN IS COMPLETELY UNLOADED. KEEP THE MUZZLE POINTED IN A SAFE DIRECTION. FAILURE TO FOLLOW THESE WARNINGS COULD RESULT IN SERIOUS INJURY OR DEATH.**

The versatility of your new shotgun can be extended with an extra barrel. Most shotgun barrels are interchangeable within a given gauge and chamber length. No special fitting is required. However, some important restrictions must be observed:

- Never use a barrel with a  $3\frac{1}{2}$ " chamber on a shotgun designed for barrels with a 3" chamber.
- Never use a barrel with a 3" chamber on a shotgun designed for barrels with a  $3\frac{1}{2}$ " chamber.
- Never use any other barrel from any other manufacturer on your shotgun. Some other brands may seem similar, but the barrels are not interchangeable.
- Never use a barrel from other Winchester shotguns, including those for the Super X®1, Super X®2 or Super X®3.

**FIGURE 16**

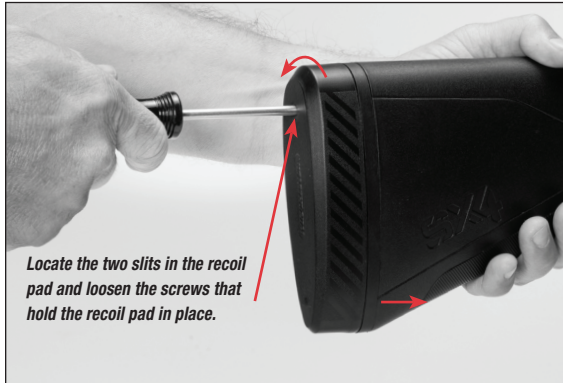

## LENGTH OF PULL ADJUSTMENT

### **⚠WARNING**

**BEFORE PERFORMING STOCK ADJUSTMENT PROCEDURES, PLACE THE “SAFETY” IN THE ON SAFE POSITION. OPEN THE ACTION AND MAKE CERTAIN YOUR SHOTGUN IS COMPLETELY UNLOADED. KEEP THE MUZZLE POINTED IN A SAFE DIRECTION. FAILURE TO FOLLOW THESE WARNINGS COULD RESULT IN SERIOUS INJURY OR DEATH.**

The stock can be adjusted for length of pull by adding or removing spacers to the rear of the stock. This applies to both composite and wood stock models. Each spacer

**FIGURE 17**



extends length of pull  $\frac{1}{4}$ " and a maximum of three spacers can be added to extend length of pull  $\frac{3}{4}$ ". With longer screws (not provided), more than three spacers can be added to further extend length of pull.

Composite stock models come from the factory with two spacers in the box. Wood stock shotguns come with one  $\frac{1}{4}$ " spacer installed, and one  $\frac{1}{4}$ " spacer in the box. Additional spacers can be ordered through your local Winchester Repeating Arms dealer or by calling our Customer Service Department at (800) 322-4626.

Length of pull can be shortened by having a gunsmith trim the stock and refit the recoil pad. Composite stock guns can be trimmed up to  $\frac{1}{2}$ ".

## TO ADJUST LENGTH OF PULL

1. Make sure your shotgun is completely unloaded and the “safety” is in the on safe position.
2. Use a #2 cross tip or Phillips screwdriver to remove the recoil pad at the end of the buttstock (Figure 16, page 27). Place a small amount of petroleum jelly on the screw access slits on the top and bottom of the rear of the buttstock to prevent damaging the recoil pad. Insert the screwdriver into each of the two access holes. Make certain the tip of the screwdriver engages the head of the screw. Turn the screw counterclockwise until the screw is completely loose from the stock. When both screws are free, remove the recoil pad.
3. Add or subtract spacers to fit your firearm to your specifications (Figure 17, page 27). After making an adjustment hold the shotgun to your shoulder to determine if the new length feels comfortable. Remember to always keep the muzzle pointed in a safe direction, the “safety” in the on safe position and the shotgun completely unloaded.
4. When you are satisfied with the length of pull, start the screws through the pad and spacer(s) into the holes in the stock.
5. Attach the recoil pad to the stock using the screwdriver. Turn the screws clockwise to tighten. Do not overtighten the screws.

## CLEANING AND MAINTENANCE SUGGESTIONS

---

### **▲WARNING**

**BEFORE PERFORMING CLEANING PROCEDURES, PLACE THE “SAFETY” IN THE ON SAFE POSITION. OPEN THE ACTION AND MAKE CERTAIN YOUR SHOTGUN IS COMPLETELY UNLOADED. KEEP THE MUZZLE POINTED IN A SAFE DIRECTION. FAILURE TO FOLLOW THESE WARNINGS COULD RESULT IN SERIOUS INJURY OR DEATH.**

### **▲WARNING**

**WEAR EYE PROTECTION WHEN DISASSEMBLING AND CLEANING YOUR SHOTGUN TO PREVENT SPRINGS, SPRING-LOADED PARTS, SOLVENTS OR OTHER AGENTS FROM CONTACTING YOUR EYES, RESULTING IN INJURY.**

### **▲WARNING**

**KEEP ALL AMMUNITION AWAY FROM THE CLEANING AREA. NEVER TEST THE MECHANICAL FUNCTION OF YOUR SHOTGUN WITH LIVE AMMUNITION. FAILURE TO FOLLOW THESE WARNINGS COULD RESULT IN SERIOUS INJURY OR DEATH.**

## CLEANING THE BARREL

Your Super X®4 shotgun will function better and more reliably over a longer period of time if it is properly maintained and kept clean. You should clean your shotgun after every day of shooting, and more often

if it becomes excessively dirty. The barrel should be cleaned and the action wiped clean and oiled after every day of shooting. The gas system should require only occasional cleaning.

Normal maintenance can be accomplished with the barrel still attached to the receiver (oiling and wiping down). More careful cleaning requires removal of the barrel from the receiver (cleaning the barrel), and the removal of the gas piston, piston sleeve and piston sleeve spring components. A complete cleaning requires removal of the bolt and trigger group.

If a malfunction occurs, perform a thorough cleaning to see if it solves the problem before seeking the services of a Winchester Repeating Arms Authorized Repair Center, the Winchester Repeating Arms Service Facility in Arnold, Missouri, or a qualified gunsmith.

1. Place the “safety” in the on safe position. Open the action and inspect the chamber and magazine to make certain they do not contain any shells. Keep the muzzle pointed in a safe direction.
2. Remove the forearm and barrel as explained under “Disassembly” on page 14.
3. Using a shotgun cleaning rod with tip and patch large enough for a snug fit in the bore, insert the rod and a lightly oiled patch in the breech end of the barrel and run back and forth through the bore several times. Remove and wipe the choke tube, threads and barrel threads with a nylon brush and lightly oil.

4. Inspect the bore from both ends for leading and plastic residue that often remains in the bores from the shot cups in modern shells. Leading and plastic residue will appear as longitudinal streaks and are usually more predominant near the muzzle and just forward of the chamber. A normal amount of either is common and not serious.
5. If leading or plastic residue seems excessive you can remove it by brushing the bore with a brass brush. Soak the brush or spray the bore with a powder solvent first. Scrub until clean. To prevent bristles from breaking off, push the brush fully through the barrel each time before pulling it back through.

**⚠WARNING**

**MOST SOLVENTS ARE HIGHLY FLAMMABLE. WEAR EYE PROTECTION AND PRACTICE APPROPRIATE SAFETY MEASURES WHEN WORKING WITH SOLVENTS TO AVOID SERIOUS INJURY.**

6. After all leading and plastic residues have been removed, run a clean, dry patch through the bore. Follow this with a final, lightly oiled patch.
7. Reassemble the shotgun and wipe all exposed metal surfaces with an oiled cloth making sure to wipe away all finger marks where moisture could accumulate.
8. Inspect the barrel and chamber to be certain no patches have inadvertently been left in them. Remove any that remain.

9. Lightly oil your firearm at the points described under “Periodic Oiling” on page 30. Regular, light oiling is extremely important to the durability and reliable operation of your shotgun.
10. The wood surfaces can also be wiped with a quality, lightweight gun oil or they can be polished with any quality furniture wax (but not both).

#### **CLEANING THE GAS SYSTEM**

1. Remove the gas piston, piston sleeve spring and piston sleeve from the magazine tube as explained in “Disassembly” on page 14.
2. Spray the magazine tube, gas piston and piston sleeve with gun solvent and brush them thoroughly with a nylon brush to remove any deposits. It will be easier to remove the piston sleeve spring to clean the interior of the piston sleeve. Spray the inside of the gas piston with solvent. A green Scotch-Brite® kitchen scrub pad works best for removal of heavy carbon fouling on the tube and inside the gas piston. Do not remove the spring inside of the piston. Never use a steel brush on any of the gas system components.
3. Complete the cleaning of the gas system by applying a light film of oil to all parts for protection and lubrication.

#### **PERIODIC OILING**

The metal parts of a firearm should receive a light film of oil after the firearm has been exposed to weather or handling.

Occasionally, a drop of lightweight gun oil may be placed inside the receiver on the rails on which the bolt slides, and on the surface of the magazine tube, where the gas piston slides. This will help relieve friction and ensure smooth operation.

If the firearm has been exposed to excessive dust, dirt, mud or water, the principal working parts (including the gas system) should be wiped clean and lubricated with a light film of quality, lightweight gun oil.

#### **NOTICE**

**DO NOT PLACE LARGE QUANTITIES OF OIL INTO THE ACTION. EXCESS OIL WILL RUN BACK INTO THE WOOD OF THE STOCK SOFTENING THE WOOD, WITH CONSEQUENTIAL LOOSENING OF THE STOCK.**

#### **SERVICING THE TRIGGER GROUP AND BOLT ASSEMBLIES**

---

#### **⚠WARNING**

**BEFORE PERFORMING CLEANING PROCEDURES, PLACE THE “SAFETY” IN THE ON SAFE POSITION. OPEN THE ACTION AND MAKE CERTAIN YOUR SHOTGUN IS COMPLETELY UNLOADED. KEEP THE MUZZLE POINTED**



**IN A SAFE DIRECTION. FAILURE TO FOLLOW THESE WARNINGS COULD RESULT IN SERIOUS INJURY OR DEATH.**

**⚠️WARNING**

**WEAR EYE PROTECTION WHEN DISASSEMBLING AND CLEANING YOUR SHOTGUN TO PREVENT SPRINGS, SPRING-LOADED PARTS, SOLVENTS OR OTHER AGENTS FROM CONTACTING YOUR EYES, RESULTING IN INJURY.**

**⚠️WARNING**

**KEEP ALL AMMUNITION AWAY FROM THE CLEANING AREA. NEVER TEST THE MECHANICAL FUNCTION OF YOUR SHOTGUN WITH LIVE AMMUNITION. FAILURE TO FOLLOW THESE WARNINGS COULD RESULT IN SERIOUS INJURY OR DEATH.**

The trigger group and bolt can be removed if the action becomes excessively dirty or wet. If this occurs, disassemble the action for a complete cleaning as explained in the following sections. The trigger group and bolt assembly of your Super X®4 shotgun are designed to be removed in the field, without special tools.

Disassembly of the action involves the removal of the bolt assembly and the trigger group. Disassembly beyond this point should only be performed by a qualified gunsmith.

**FIGURE 18**



**REMOVING THE TRIGGER GROUP**

1. Place the bolt in the forward position by holding the bolt handle and depressing the bolt release button.

**NOTICE**

**NEVER ALLOW THE ACTION TO SLAM CLOSED BY PRESSING THE BOLT RELEASE BUTTON WITHOUT THE BARREL INSTALLED. IF THE BOLT IS RELEASED FORWARD WITH THE BARREL REMOVED, THE BOLT HANDLE WILL HIT THE RECEIVER AND CAUSE DAMAGE.**

2. Use a punch or similar object to push inward on the trigger group pins, taking care not to scratch the receiver. Trigger group pins may be removed from

**FIGURE 19**



either side of the receiver. Push the trigger group pins through the receiver. Pull on them from the opposite side to remove them (Figure 18, page 31).

3. Grasp the trigger guard and pull it up and out of the receiver (Figure 19, page 32).
4. Perform any cleaning of the parts and receiver cavity as necessary. We suggest cleaning the trigger group with a quality aerosol gun solvent. Allow it to dry and then very lightly oil the moving parts.

**NOTICE**

**DO NOT DISASSEMBLE THE TRIGGER GROUP BEYOND THIS POINT.**

**FIGURE 20**

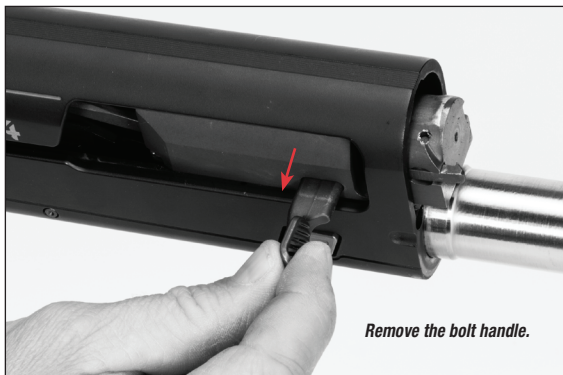

**REINSTALLING THE TRIGGER GROUP**

1. Make sure the bolt is in the forward position.
2. Insert the trigger group into the receiver. Align the holes in the trigger group with the holes on each side of the receiver.
3. Reinsert the trigger group pins and gently tap them into place with a plastic or wooden mallet, again using caution not to scratch the receiver.

**REMOVING THE BOLT ASSEMBLY**

1. Remove the trigger group as explained on pages 31-32.
2. Pull the bolt handle to the rear until the bolt locks in the open position.

**FIGURE 21**

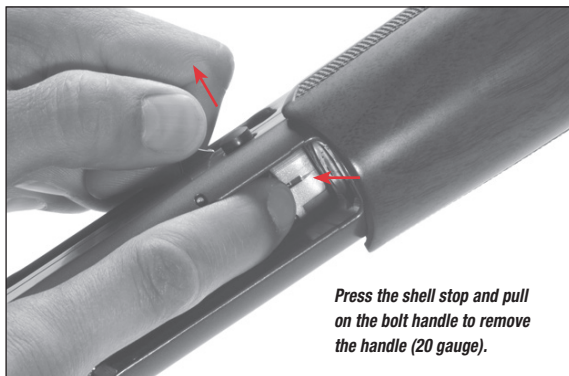

3. Remove the barrel, gas piston, piston sleeve and piston sleeve spring as explained previously.
4. Place the bolt in the forward position by holding the bolt handle and pressing the bolt release button.

**NOTICE**

**NEVER ALLOW THE ACTION TO SLAM CLOSED BY PRESSING THE BOLT RELEASE BUTTON WITHOUT THE BARREL INSTALLED. IF THE BOLT IS RELEASED FORWARD WITH THE BARREL REMOVED, THE BOLT HANDLE WILL HIT THE RECEIVER AND CAUSE DAMAGE.**

**FIGURE 22**



5. On 12 gauge models, remove the bolt handle by pulling it outward (Figure 20, page 32).  
On 20 gauge models, remove the bolt handle by holding the shotgun with the loading port up. Press the shell stop while pulling outward on the bolt handle (Figure 21, page 33).
6. On 12 gauge models, slide the bolt assembly forward and out of the receiver (Figure 22, page 33).  
On 20 gauge models, press the shell stop and slide the bolt and bolt slide forward and out of the receiver.
7. The bolt and bolt slide can be separated for cleaning (Figure 23, page 34). Perform any cleaning of the bolt and receiver cavity as necessary.

**FIGURE 23**

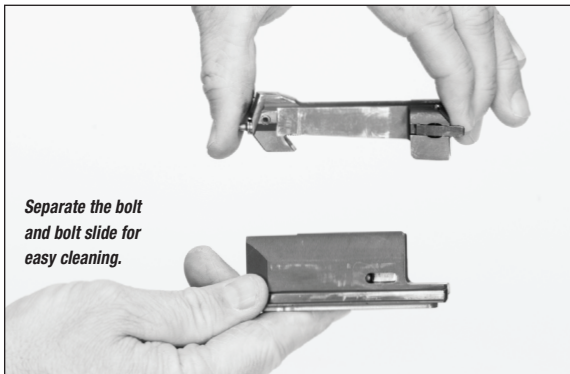

**NOTICE**

**DO NOT DISASSEMBLE THE BOLT ASSEMBLY BEYOND THIS POINT.**

**REINSTALLING THE BOLT ASSEMBLY**

1. Reassemble the bolt and bolt slide (Figure 24, page 34).
2. Place a few drops of oil in the grooves to lubricate the bolt slide rails (Figure 3, page 9). Align the rails on the bolt slide with the grooves in the bottom of the receiver and place the bolt assembly back in the receiver, bolt slide link end first (Figure 25, page 35).
3. Guide the bolt slide link into its socket in the recoil spring follower (Figure 26, page 35).

**FIGURE 24**

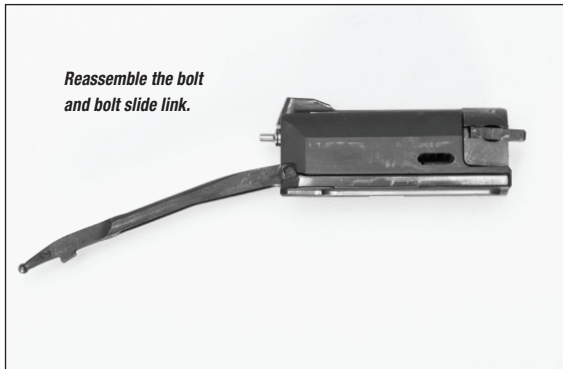

4. On 12 gauge models, replace the bolt handle by inserting it in its slot in the bolt.  
On 20 gauge models, replace the bolt handle by holding the shotgun with the loading port up and pressing the shell stop while inserting the bolt handle into the slot.  
**IMPORTANT:** On 20 gauge models, it may be necessary to pull out on the bolt handle slightly until the shell stop clicks back in place. Failure to follow these instructions will result in the inability to load the magazine.
5. Open and close the action several times to make sure the bolt slide link and recoil spring follower are properly engaged.

**FIGURE 25**



**NOTICE**

**NEVER ALLOW THE ACTION TO SLAM CLOSED BY PRESSING THE CARRIER RELEASE BUTTON WITHOUT HAVING THE BARREL INSTALLED. DAMAGE WILL RESULT TO THE RECEIVER AND BOLT HANDLE.**

**CLEANING THE ACTION**

1. When the action becomes excessively dirty, remove the trigger group and bolt assembly from the receiver as explained under “Servicing the Trigger Group and Bolt Assemblies” beginning on page 30. Clean with a gun solvent as necessary, using a nylon brush to loosen any caked-on grime.

**FIGURE 26**

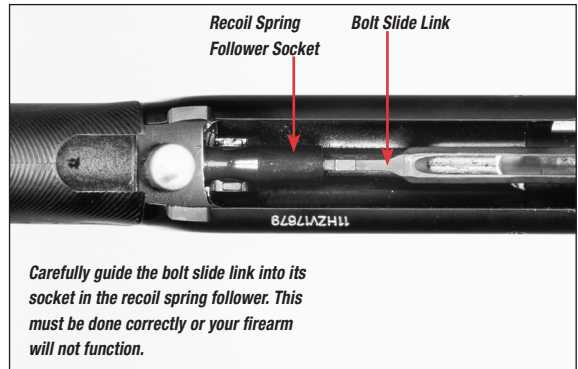

Wipe the receiver cavity clean. Lightly oil the cavity and wipe it dry. No further disassembly is required for cleaning.

2. Reassemble the trigger group, bolt assembly, gas system and the barrel to the receiver as explained previously. Then wipe all exposed metal surfaces with an oiled cloth, making sure to wipe clean all finger marks where moisture could accumulate.
3. The barrel and action should be inspected thoroughly to be certain no cleaning patches have been inadvertently left in them.

### *CLEANING THE INVECTOR-PLUS™ CHOKE SYSTEM*

1. Never use a brass brush to clean your barrels unless choke tubes are installed. Bristles could break off and lodge in the threads, making installation and removal of the choke tubes difficult.
2. Regularly remove the choke tubes to clean and oil the threads inside the barrel, as well as on the choke tube itself. This will protect the threads from being damaged and also prevent a dirt build-up that would cause the choke tube to become difficult to remove. Clean the threads with solvent and a small, soft brush like a toothbrush. Wipe completely clean and leave a thin film of clean oil on the threads, both on the tube and in the barrel. The threads of the choke tube and the internal threads of the barrel should be cleaned after each use and before the installation of a tube.
3. Be careful when removing/installing a choke tube. Use only the specially designed wrench. Damage can result to both the choke tube and barrel when attempting to remove or install choke tubes.
4. Never fire your shotgun or run cleaning tools through the barrel of any choke-tubed shotgun without having the choke tubes installed.

#### **NOTICE**

**NEVER ATTEMPT TO TAKE YOUR FIREARM APART FURTHER THAN EXPLAINED IN THIS OWNER'S MANUAL. YOUR FIREARM IS A SPECIALIZED, FINELY FITTED**

**MECHANISM. YOU MAY PERMANENTLY DAMAGE IT BY ATTEMPTING TO DISASSEMBLE THE INNER MECHANISM. IF FURTHER DISASSEMBLY FOR SERVICE OR CLEANING IS REQUIRED, TAKE YOUR FIREARM TO A QUALIFIED GUNSMITH, OR CONTACT OUR ARNOLD, MISSOURI SERVICE FACILITY AS EXPLAINED UNDER "PARTS, SERVICE, REPAIR AND QUESTIONS."**

#### *OTHER SUGGESTIONS*

After extended periods of heavy use, your firearm should be taken to a qualified gunsmith to have the action disassembled for professional cleaning and lubrication.

#### *PARTS, SERVICE, REPAIR AND QUESTIONS*

If your Winchester firearm should ever need service or repair, it is often best to utilize one of our Authorized Repair Centers. In some cases it is appropriate to use the Winchester Repeating Arms Service Facility in Arnold, Missouri. If you need a new listing, contact us. We can help you determine the best place to service your firearm.

In order to avoid delays, it is important to never send your firearm directly to our facility without direct authorization from one of our service specialists. This avoids possible delays in obtaining service. Contact us at (800) 322-4626 for details on how to receive service before sending your firearm.

Parts listings, Authorized Repair Center lists, service procedures, service/repair form and general product information are also found on the web at [winchesterguns.com](http://winchesterguns.com).

When returning your firearm for servicing, you must do the following:

1. Be sure it is completely unloaded.
2. Remove the scope or other optics.
3. Package it securely in a cardboard container.
4. Enclose the service/repair form available at [winchesterguns.com](http://winchesterguns.com) or a letter that clearly describes the trouble experienced, the ammunition used and the repairs desired. Also include your name, email address (if possible) and a daytime phone number where you can be reached.
5. If convenient, send a copy of the service/repair form or letter to us separately.
6. Never return ammunition with your firearm. It is against postal and most commerce regulations.

#### **PARTS, SERVICE, REPAIR STATUS AND TECHNICAL QUESTIONS**

**Winchester Repeating Arms  
Parts and Service**  
3005 Arnold Tenbrook Road  
Arnold, MO 63010-9406  
(800) 322-4626

#### **GENERAL PRODUCT AND HISTORICAL QUESTIONS**

**Winchester Repeating Arms  
Customer Service**  
275 Winchester Avenue  
Morgan, UT 84050-9333  
(800) 945-5237

#### **▲WARNING**

**PARTS ARE MADE FOR WINCHESTER BRAND FIREARMS  
MANUFACTURED BY OR FOR WINCHESTER REPEATING  
ARMS, AND SHOULD NOT BE USED IN OTHER FIREARMS,  
EVEN THOUGH MODELS MAY BE SIMILAR. IMPROPERLY  
FITTED PARTS MAY BE DANGEROUS. FAILURE TO  
FOLLOW THIS WARNING MAY CAUSE INJURY OR DEATH  
AND CAUSE DAMAGE TO YOUR SHOTGUN.**

#### **WEBSITE INFORMATION**

---

An information resource for Winchester Repeating Arms can be found online.

- List of Authorized Repair Centers.
- Customer Service information.
- Firearm Service/Repair Form.
- Answers to many technical and historical questions.
- Links to helpful sites.

Go to [winchesterguns.com](http://winchesterguns.com)



Winchester Repeating Arms

275 Winchester Avenue

Morgan, UT, U. S. A. 84050-9333

[winchesterguns.com](http://winchesterguns.com)

AO1810/18361

Winchester is a registered trademark of Olin Corporation.